

Features

- Lightweight black anodized aluminum cone
- Fully shielded magnetic structure
- Attractive 6-hole cast frame
- Advanced low distortion motor design
- Solid aluminum phase plug
- Rubber surround

Parameters

| | |
|-----------------------------|-----------|
| Impedance (Ω) | 8 |
| Re (Ω) | 6.4 |
| Le (mH) @ 1 kHz | 0.94 |
| Fs (Hz) | 26.9 |
| Qms | 1.42 |
| Qes | 0.53 |
| Qts | 0.38 |
| Mms (g) | 30.52 |
| Cms (mm/N) | 1.15 |
| Sd (cm ²) | 216.4 |
| Vd (liters) | 151.5 |
| BL (Tm) | 8.03 |
| VAS (liters) | 75.3 |
| XMAX (mm) | 7 |
| VC Diameter (mm) | 38 |
| SPL (dB@1W/1m) | 88.1 |
| RMS Power Handling (w) | 80 |
| Usable Frequency Range (Hz) | 27 - 2000 |

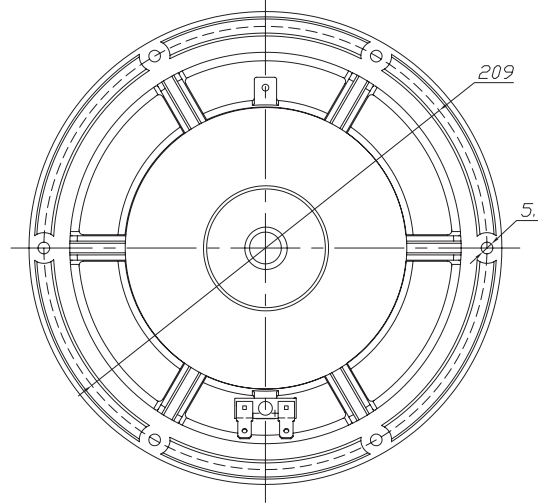
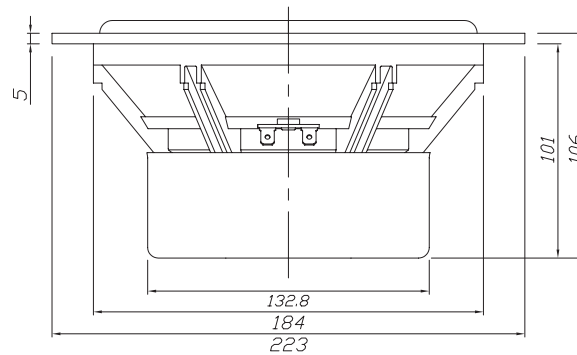

Note: All dimensions in mm.

Frequency Response

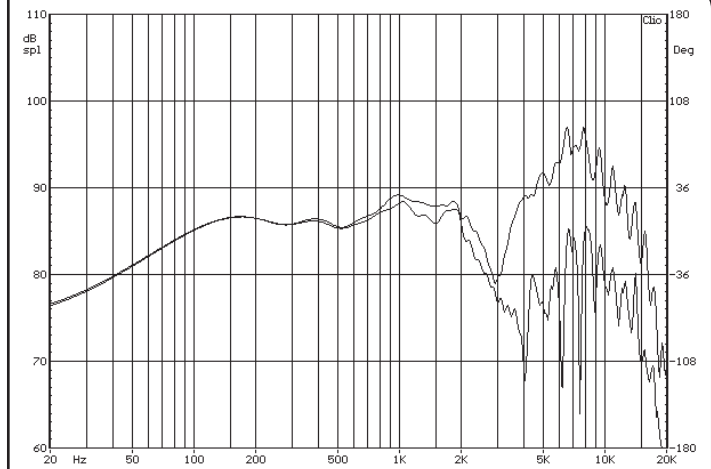

Note: Due to testing limitations, response below 200 Hz is not an actual representation.

Impedance/Phase

