

SD315-88**12" Shielded DVC Subwoofer****SD315-88****12" Shielded DVC Subwoofer****Features**

- 12" heavy duty paper cone
- Magnetically shielded
- Durable rubber surround
- Dual 8 ohm voice coils
- High power motor structure
- Long-throw design
- Well suited for both sealed and vented designs

Parameters

Impedance (Ω)	4
Re (Ω)	3.0
Le (mH) @ 1 kHz	1.31
Fs (Hz)	26.9
Qms	3.44
Qes	0.38
Qts	0.34
Mms (g)	109.2
Cms (mm/N)	0.32
Sd (cm ²)	522.8
Vd (liters)	366.0
BL (Tm)	12.07
VAS (liters)	122.8
XMAX (mm)	7
VC Diameter (mm)	51
SPL (dB@1W/1m)	90.5
RMS Power Handling (w)	120
Usable Frequency Range (Hz)	25 - 1000

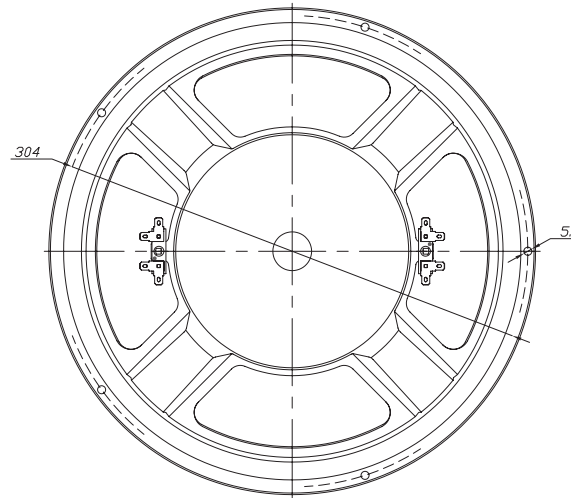
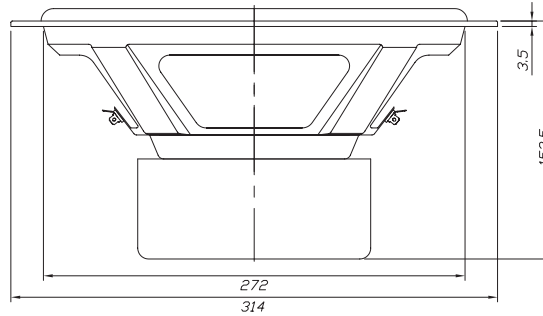

Note: All dimensions in mm.

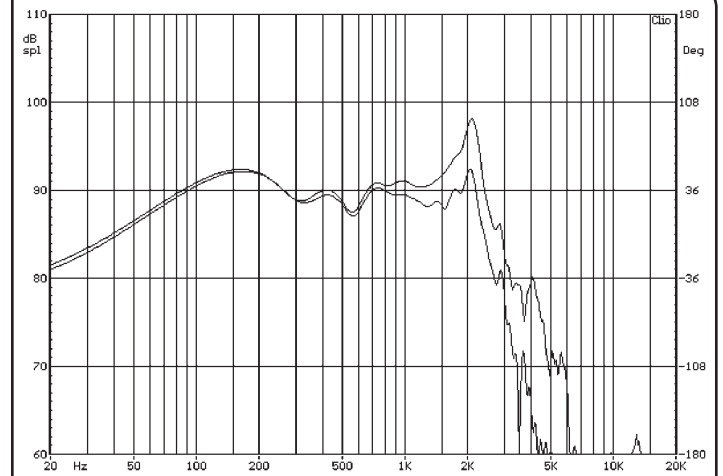
Frequency Response

Note: Due to testing limitations, response below 200 Hz is not an actual representation.

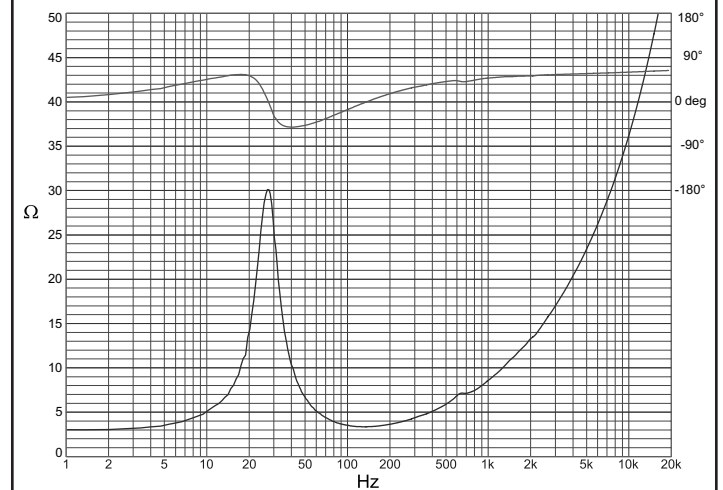
Impedance/Phase

daytonaudio.com

© Dayton Audio