

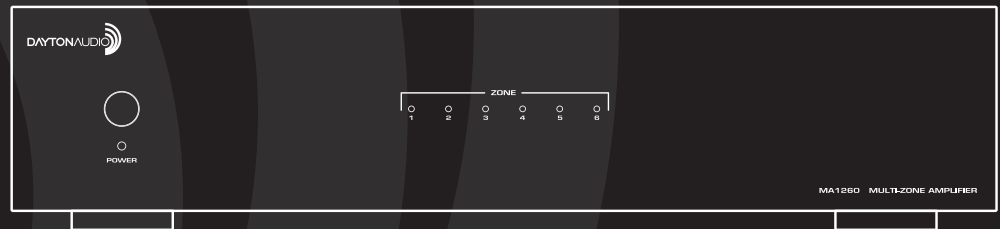

TWELVE CHANNEL MULTI-ZONE AMPLIFIER

Model: MA1260 User Manual



Thank you for purchasing the Dayton Audio® MA1260 Twelve Channel Multi-Zone Amplifier. The versatility of the MA1260 makes it the perfect choice for almost every type of custom multi-room audio system. Its tabletop or rack-mountable design allows it to be integrated easily into high-end whole house audio systems.

FEATURES:

- 12 channels (6 stereo zones) in one convenient enclosure
- Efficient Class D design delivers superior audiophile sound quality and performance
- Independent and bus inputs provides unparalleled flexibility
- Bridgeable channel outputs provide additional power when needed
- Independent channel gain controls allow the output of each speaker to be perfectly matched
- Switchable 115/230V input voltage
- Manual, auto, or triggered on/off for integration into any automated system
- Multi-stage protection circuitry for reliability and easy troubleshooting of audio system
- Installer-friendly setup and connections
- Can be converted easily between rack-mount and tabletop configurations
- Heavy-duty steel chassis with brushed aluminum faceplate

INSTALLATION:

Dayton Audio amplifiers are designed to help deliver a great audio experience. However, where you place the amplifier can have a large effect on the performance you receive, and the life of the unit. If you are not rack-mounting the amplifier, position it with all feet resting on a solid level surface. Be sure that the amplifier is in a well-ventilated area and **DO NOT** install the amplifier near a source of heat or in an extremely humid or wet location.

CAUTION: All connections and switching must be done with the amplifier’s power switch positioned to ‘Off’. Connect the power cord last to be sure that the amplifier is off during all of your connections and set up.

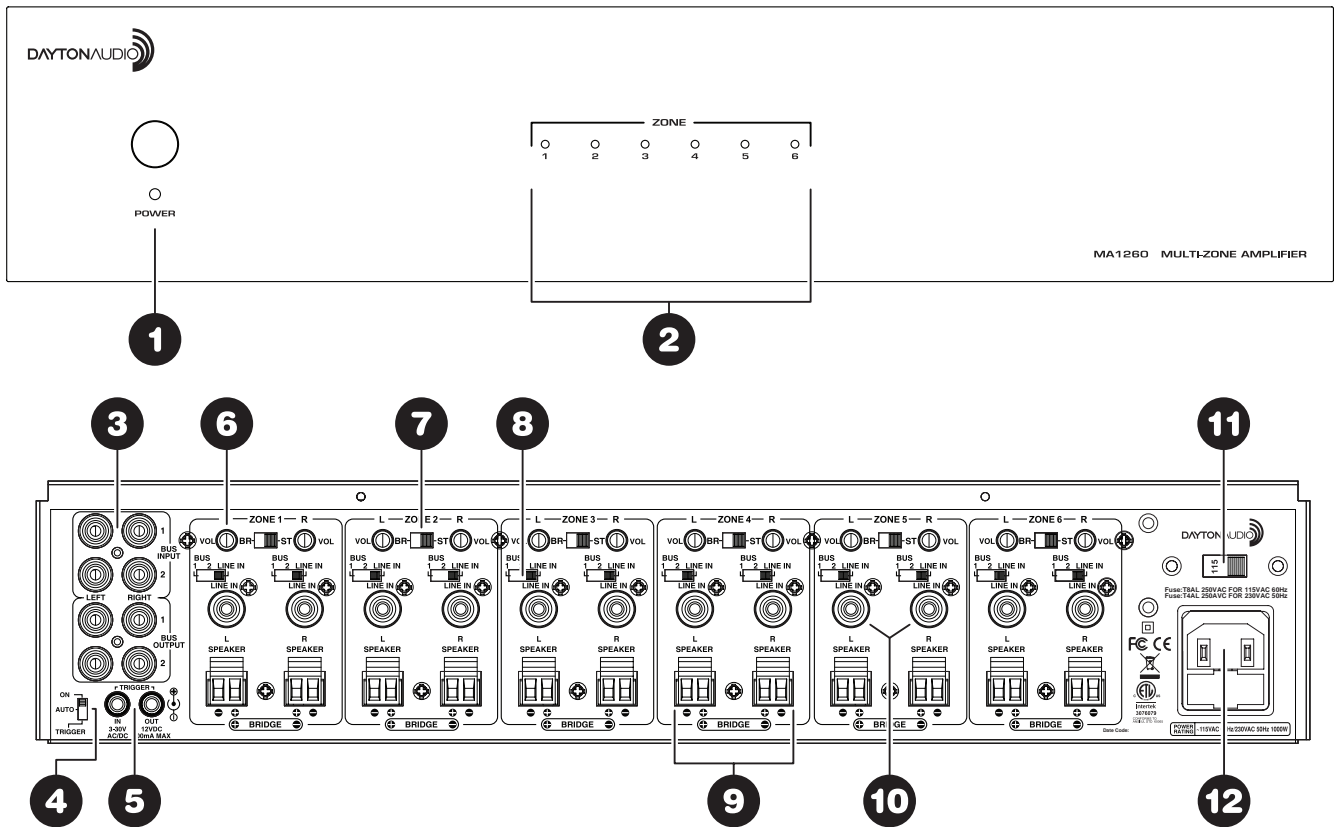

FRONT PANEL:

1. Master Power Switch / Indicator LED

Front panel pushbutton power switch turns the amplifier on and off. When the switch is on and the indicator LED is red, the amplifier is in standby mode. The remote turn on switch (located on the rear) is either in the “trigger” or “auto” position. When the LED is blue, the amplifier is fully active. The master power switch will turn off the amplifier no matter which power mode has been selected.

2. Zone Status Indicators

Each pair of channels or zones has a bi-color LED to

indicate its operational status. These indicators provide quick and easy troubleshooting of the system. If the circuitry determines that a channel must be shut down due to excessive heat or low impedance (a short), only the channels that are affected will be turned off causing the zone LED to turn red. The remaining zones will continue to operate and maintain a blue LED status. Once the condition has been corrected for the zone in question, the status LED will return to blue.

Note: When the power LED is red and the zone status LEDs are not lit (off), this indicates the unit is in standby mode.

REAR PANEL:

3. BUS Line Inputs / Outputs

The MA1260 has two common or BUS inputs that receives audio signals from standard line-level audio sources and sends them to any or all channels. The BUS line outputs are direct feed-through to allow the BUS inputs to be fed to other amplifiers. Be sure to use high quality RCA cables that feature low impedance, shielding and high quality connectors.

4. Remote Turn-On Switch

This switch selects the turn-on stimuli that will put the amplifier in ready mode. "Trigger" setting relies on 3-30V AC/DC voltage going into the trigger input to activate the amplifier. "Auto" setting senses a signal on the RCA line-level inputs and automatically puts the amp in ready mode. "On" setting puts the amp constantly in ready mode so that it can be controlled by the master power switch on the front panel. In "Auto" mode, the amplifier will take approximately 15 minutes to return from ready to standby mode.

5. Trigger Input / Output

The trigger input is a handy feature when connecting the amplifier to an automated audio system. The 3.5mm mini-plug jack will accept a 3-30V AC/DC output from another device, or from a separate power supply. When the trigger input is energized, the amp turns from standby to ON mode. When using the MA1260 with a receiver without a trigger output, the voltage can come from a 12V wall wart (3.5mm tip-positive connector) plugged into the receiver's switched outlet and the trigger input. The MA1260 can also provide an output trigger voltage (12DC @500mA max.) to turn on and off other devices in the audio system. When the amplifier turns off (standby mode), the voltage will drop to zero.

Note: Remember there is a delay of approximately 15 minutes before the amplifier goes to standby when using the "Auto" turn-on mode.

6. Channel Gain Control

Each channel has its own independent level adjustment. This allows the output level of each speaker to be perfectly matched to its area. It can also be used to limit the maximum audio level in a certain area.

7. Bridging Switch

By simply flipping a single switch, two channels can be combined to increase the total power output. This is helpful when extra power is needed in certain areas.

Note: The minimum impedance for bridged channels is 8 ohms. Also, please observe the proper speaker wiring when bridging channels. Input selection and volume settings for bridged channels will be controlled by the left channel. "BR" is bridged mode and "ST" is non-bridged or stereo mode.

CAUTION: Only change switch positions when the amplifier is turned off.

8. Input Selection Switch

Each channel is capable of delivering the source from many inputs. The three main inputs are BUS 1, BUS 2 and LINE IN. The selection for these inputs is done via the Input Selection switch associated with each channel. Select the desired source input. Set the Input Selection switch to BUS 1 (will play source connected to the BUS 1 input), BUS 2 (will play source connected to the BUS 2 input) or LINE IN (will play source connected to that channel's LINE IN).

CAUTION: Only change switch positions when the amplifier is turned off.

CLOSE UP OF CONNECTIONS

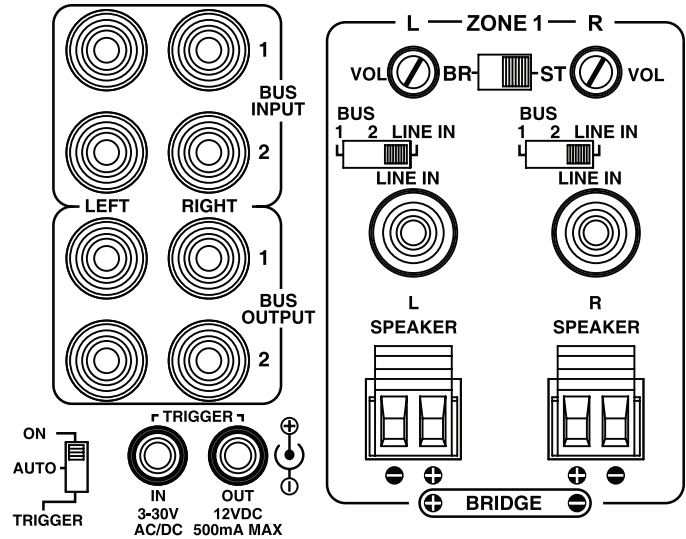

9. Speaker Output Terminals

The MA1260 uses high quality Phoenix style connectors for the speaker connections. Use 14-18 gauge stranded two-conductor loudspeaker wire. Ensure that at least 2 inches of each conductor are separated. Strip away ¼ inch of insulation from each conductor. Connect the appropriate conductor to each screw terminal, observing correct polarity. Also, please observe proper speaker wiring when bridging channels.

10. Individual Channel Input

All twelve channels have their own dedicated input that allows the connection of audio sources in addition to the common BUS inputs. This is useful when using the MA1260 with an audio matrix switcher.

11. AC Voltage Switch

The unit is set at the factory for 115V U.S. operation; simply connect the included IEC power cord to your wall outlet. For 230V operation, move the voltage selector switch to the 230V position. When operating at 230V the internal fuse located in the IEC socket should also be changed. In most 230V applications a separate power cord will be required and is not included.

12. IEC Power Connector

The unit comes with an IEC jack that permits removal of the AC power cord. This allows the flexibility of changing the power cord for different countries. The IEC socket also houses the main fuse holder. Plug the power cord supplied with the amplifier into the amplifier and wall outlet or appropriate surge protector.

CAUTION: DO NOT plug the amplifier's power cord into a switched outlet, such as what is provided on some Surround Receivers. If you wish to have the amplifier turn on when the Receiver is powered up, use one of the power modes, such as Trigger or Auto.

TYPICAL 6-ROOM INSTALLATION

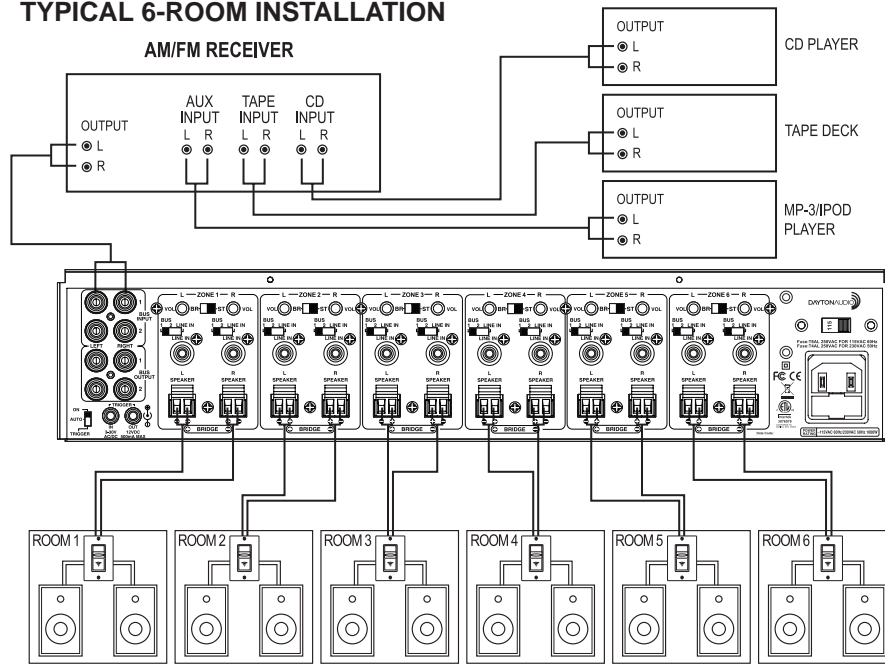

NOTES ABOUT HUM:

While the MA1260 has been designed to minimize the possibility of hum in the audio system, it is still possible that a hum will occur in rare circumstances. Its safety grounding can create a path for small amounts of 60 Hz energy to travel through the line-level audio system. While not dangerous, this energy can cause difficulty with the auto signal sensing circuit, and at the very least will interfere with the quiet enjoyment of your system. The first course of action should be trying to make sure that all of the audio components are connected to either the same electrical outlet, or at least into the same circuit branch. Next, cable TV systems are notoriously the culprit, so be sure to try disconnecting all coaxial feeds that are connected to the system. If this solves the problem, install a coaxial line isolator and reconnect the system. In the very worst case, a line-level audio isolator/transformer connected to the line-in of the amplifier will usually solve the problem.

SPECIFICATIONS:

| | |
|----------------------------------|---|
| Rated Power Output: | 65 Watts per channel at 8 ohms 89 Watts per channel at 4 ohms (limited by heat and PSU) |
| Bridged Power Output: | 130 Watts per channel RMS at 8 ohms (8 ohm minimum) |
| Input Sensitivity: | 450 mV for full output with all level controls at max. |
| Input Impedance: | 16.7K ohm |
| Frequency Response: | 7.5 Hz to 48 kHz |
| Distortion: | .032% THD 20 Hz-20 kHz @ 65W (4 ohm) |
| Distortion (Bridged): | .080% THD 20 Hz-20 kHz @ 130W (8 ohm) |
| Channel Crosstalk: | 94 dB |
| Signal to Noise Ratio: | 115 dB A-weighted |
| Efficiency: | 93% |
| Power Requirements: | 115/230 VAC, 50 Hz/60 Hz |
| Stand-By Power Rating: | 115V, 0.46W * |
| Auto Turn-On Sensitivity: | 12.3mV |
| Dimensions: | 16.7" W x 4" H (including feet) x 14.25" D |
| Weight: | 40 lbs. |

* The MA1260 complies with the ENERGY STAR and CE EuP directive.

IMPORTANT SAFETY INSTRUCTIONS

To reduce the risk of electric shock, do not remove cover. No user serviceable parts inside. Refer servicing to qualified personnel. To reduce the risk of fire and shock do not expose unit to rain or moisture. The unit should be connected to an earth grounded AC electrical socket. The unit should be operated in a well ventilated area. Minimum clearance is 2 inches from the ventilation openings.

Note: Unit is set at the factory for 120V operation. Be sure to change the fuse (4A rating) before switching to 230V operation.



Warranty Information

Dayton Audio products are warranted free from defects in material and workmanship for **5 years** from date of purchase (see exceptions below). In the rare case of a product failure, please contact your place of purchase or call our Customer Support Department at (937) 743-8248.

Warranty Limitations

There are no other warranties, either express or implied, that extend the foregoing, and there are no warranties of merchantability or fitness for any particular purpose. Dayton Audio is not responsible for any consequential or incidental damage to any other unit or component or the cost for installation or extraction of any component of the audio system, or for the improper use of products. This includes but is not limited to burnt voice coils, overheating, bent frames, holes in the cone, or broken lead wires. Warranty does not apply to misuse, abuse, neglect, accident, improper use, etc. Dayton Audio reserves the right to repair or replace the products with either a new or factory refurbished unit.

Exception: Dayton Audio HDMI Cables -- No registration, no questions asked LIFETIME warranty. Replacement of Dayton Audio HDMI cables is with equal or better quality HDMI cables. Unassembled Kits - A 45-day return policy applies to unassembled kits. Once assembly has been started or completed, kits are deemed used and are nonreturnable for refund/exchange. This does not limit the manufacturers' warranty policies on any kit component.

This warranty gives you specific legal rights and you may also have other rights that vary from state to state.

Non-Warranty Service: If non-warranty service is required, the product may be sent to the Company for repair/replacement, transportation prepaid, by calling (937) 743-8248 for details, complete instructions, and service fee charges.



daytonaudio.com
tel + 937.743.8248
info@daytonaudio.com

705 Pleasant Valley Dr.
Springboro, OH 45066
USA



© Dayton Audio® Last Revised: 4/26/2016